

# Grade 6

Assessment of Reading, Writing and Mathematics, Junior Division

## Student Booklet

# Mathematics

SPRING 2010

**RELEASED ASSESSMENT QUESTIONS**

Record your answers on the Multiple-Choice  
Answer Sheet.

Education Quality and  
Accountability Office



Please note: The format of  
this booklet is different from  
that used for the assessment.  
The items themselves remain  
the same.

# **Mathematics**

## **Section 1**

- 1** Zach lives in a city with a population of ninety-two thousand forty-seven. Which number below represents the population of this city?

a 9247  
 b 92 470  
 c 92 047  
 d 920 047

- 2** Emily makes a table of values using the following rule:

Start with 2 and add 3 to get the next term.

Term number	Term
1	2

Which ordered pair belongs in her table of values?

a (4, 8)  
 b (4, 9)  
 c (4, 11)  
 d (4, 14)

- 3** Enrico pours 80 L of water into 200 mL cups. If he fills the cups completely, how many cups does he fill?

a 250  
 b 400  
 c 2500  
 d 4000

- 4** Which parallelogram has an area of  $24 \text{ m}^2$  and a perimeter of 28 m?

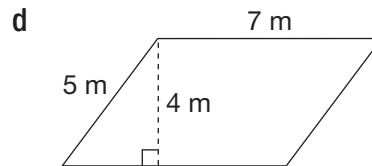
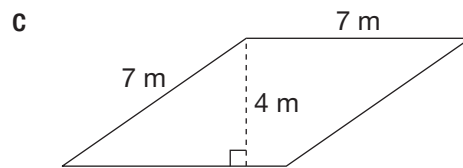
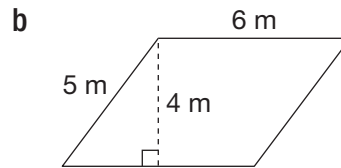
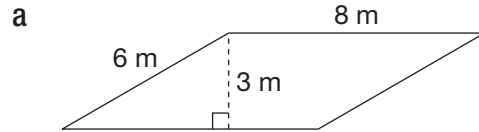

- 5** A number divided by 58 is close to 30.

Which of the following could be this number?

a 18.43  
 b 184.3  
 c 1843  
 d 18 430

- 6** Shape P is reflected across the dotted line and then rotated 90° clockwise.

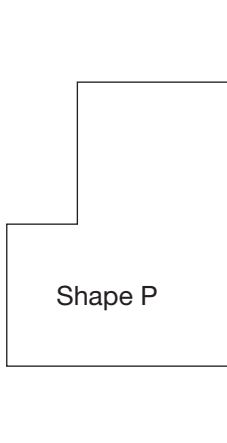

Which shape in the diagram below is an image of Shape P after these two transformations?

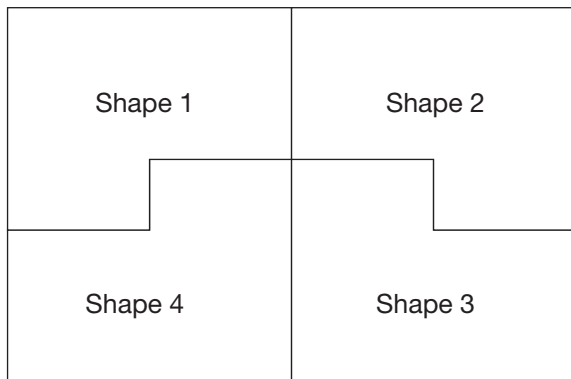

- a Shape 1
- b Shape 2
- c Shape 3
- d Shape 4

**7** Sydney makes the figure below with 6 linking cubes.

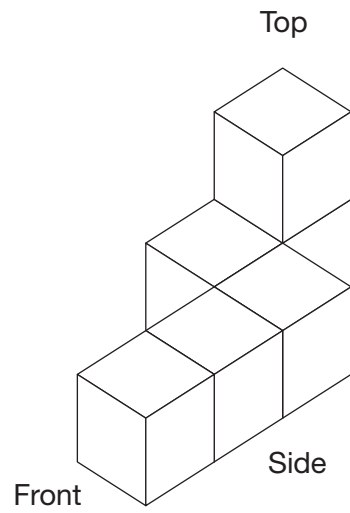

Draw a top, a front and a side view of Sydney's figure on the grid below.

Top View					Front View					Side View							

- 8** Consider the fractions shown below.

$$\frac{3}{4}, \frac{18}{25}, \frac{15}{20}, \frac{75}{100}$$

Which fractions represent equal values?

Justify your answer.

- 9 Eric and Todd take 4 science tests. The table below shows Eric's 4 scores and 2 of Todd's scores.

Science Test Scores

Student	Test 1	Test 2	Test 3	Test 4	Mean test score
Eric	86	79	85	82	
Todd		85		89	

Todd's mean for the four tests is five points higher than Eric's. Complete the table above by entering Todd's mean test score and possible scores for his Test 1 and Test 3.

Justify your answers.

- 10** Determine the area of the unshaded part of the rectangle below. Use a ruler.

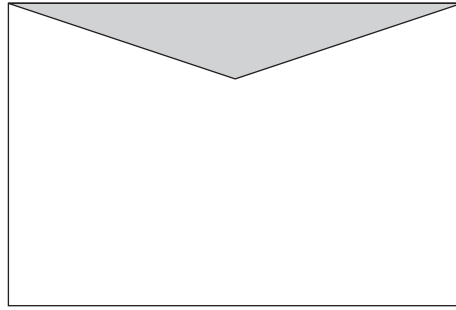

Justify your answer.

The area of the unshaded part of the rectangle is \_\_\_\_\_.



- 11** Ten students in Mr. Smith's class record their height and the length of their feet. The graph below displays these data.

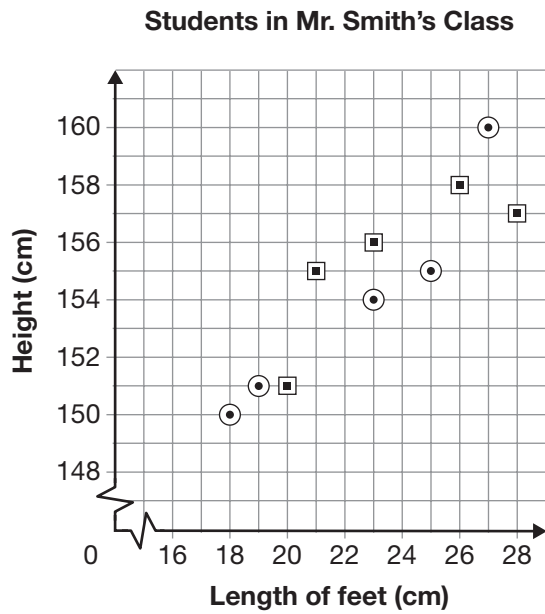

Key	
○	represents a boy
□	represents a girl

Which conclusion can be drawn from the data?

- a A boy has the longest feet.
- b A girl has the smallest feet.
- c Taller students tend to have smaller feet.
- d Shorter students tend to have smaller feet.

- 12** The faces on a fair number cube are labelled 1, 2, 3, 4, 5 and 6. Steven rolls the number cube 48 times.

How many times should Steven expect to roll a 3?

- a 3
- b 8
- c 16
- d 24

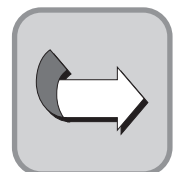

- 13** Mr. Christy records the number of sit-ups the students in his class can do in one minute. The table below shows the results for 8 students.

**Mr. Christy's Class**

Name	Number of sit-ups
Caleb	23
Mireille	34
Jochen	43
Pavel	22
Abdul	43
Sebastian	32
Marina	23
Yusef	33

Which stem-and-leaf plot displays the same data?

- a** **Number of Sit-ups**

Stem	Leaf
2	2 3
3	2 2 3 4 4
4	4

- b** **Number of Sit-ups**

Stem	Leaf
2	2 3
3	2 3 4
4	3

- c** **Number of Sit-ups**

Stem	Leaf
2	2 3 3
3	3 3 4
4	3 4

- d** **Number of Sit-ups**

Stem	Leaf
2	2 3 3
3	2 3 4
4	3 3

- 14** Look at the equation below.

$$y \div z = 9$$

Which values of  $y$  and  $z$  do **not** make the equation true?

- a**  $y = 27; z = 3$
- b**  $y = 54; z = 6$
- c**  $y = 63; z = 7$
- d**  $y = 72; z = 9$

- 15** The table below shows the widths and heights of 5 towers made of blocks.

**Tower Building**

Tower	Width (number of blocks)	Height (number of blocks)
1	3	2
2	5	5
3	7	8
4	9	11
5	11	14

If the towers continue to be built using the same pattern, for which tower will the difference between the width and the height be 7 blocks?

- a** Tower 7
- b** Tower 8
- c** Tower 9
- d** Tower 10

- 16** Polygon PQRT is rotated  $90^\circ$  clockwise about Point Q. What are the new coordinates of Point R after this rotation?

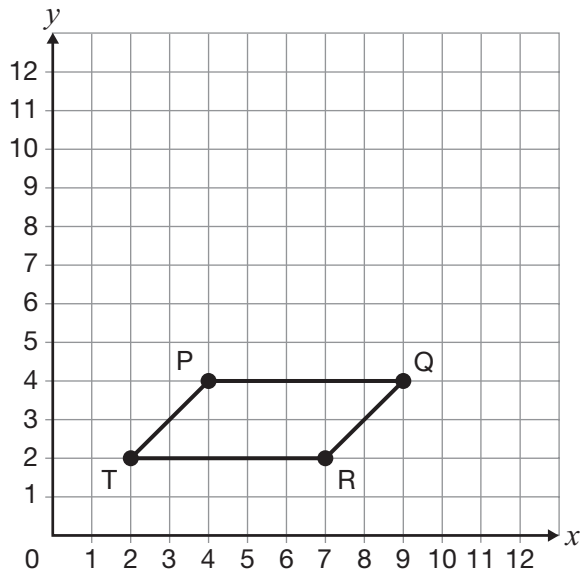

- a (6, 7)  
 b (7, 6)  
 c (11, 2)  
 d (11, 6)
- 17** A polygon has 4 sides. Two of the sides are parallel and two are not. What shape is the polygon?
- a square  
 b rhombus  
 c trapezoid  
 d parallelogram

- 18** Which angle appears to measure  $140^\circ$ ?

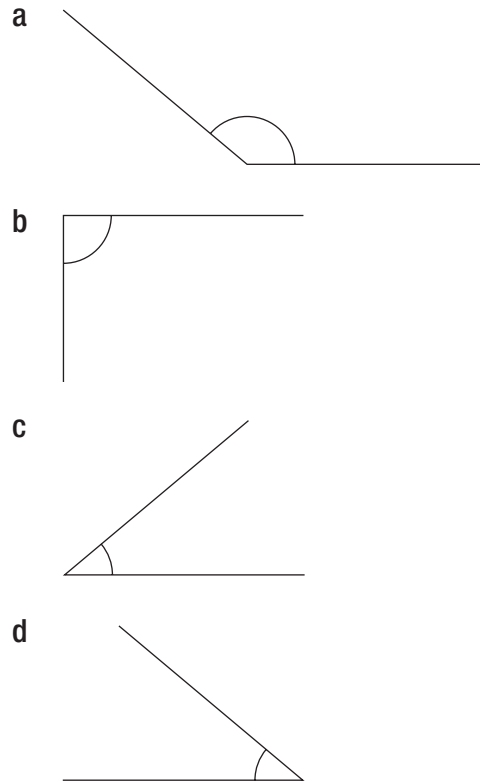

# **Mathematics**

## **Section 2**

**19** Which unit of measure is most appropriate to describe the length of a page in a textbook?

- a centimetre
- b kilometre
- c metre
- d millimetre

**20** The 4 arrows below repeat in this order to make a pattern.

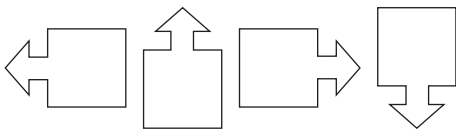

Which arrow is the 74<sup>th</sup> term?

- a
- b
- c
- d

**21** Which is equivalent to  $1 \text{ m}^2$ ?

- a  $10 \text{ cm}^2$
- b  $100 \text{ cm}^2$
- c  $1000 \text{ cm}^2$
- d  $10\,000 \text{ cm}^2$

**22** Look at the two parallelograms below.

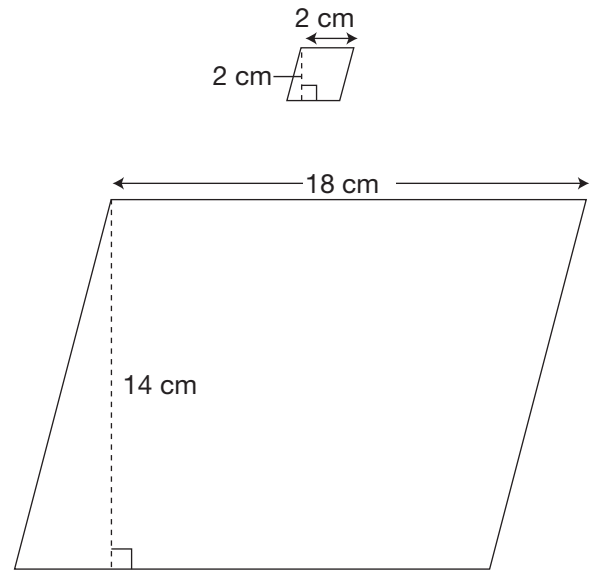

What is the minimum number of small parallelograms needed to cover the larger parallelogram completely?

- a 16
- b 63
- c 126
- d 252

**23** Which operation is a correct first step to simplify the expression below?

$$44 + 10 \div 5 - 3 \times 2 + 1$$

- a  $2 + 1$
- b  $5 - 3$
- c  $10 \div 5$
- d  $44 + 10$

**24** A turkey weighs 9.75 kilograms. It takes about 20 minutes to cook 500 grams of this turkey. Approximately how many minutes does it take to cook the whole turkey?

- a 39
- b 74
- c 390
- d 488

**25** Sara draws shaded squares on separate pieces of paper. The areas of the first three shaded squares are shown below.



1st square

Area =  $144 \text{ cm}^2$

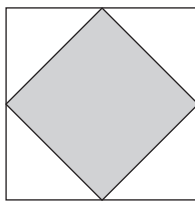

2nd square

Area =  $72 \text{ cm}^2$

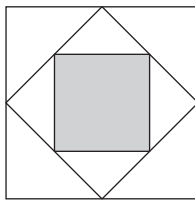

3rd square

Area =  $36 \text{ cm}^2$

If this pattern continues, what will the area of the 6th shaded square be?

- a  $2.25 \text{ cm}^2$
- b  $4.5 \text{ cm}^2$
- c  $9 \text{ cm}^2$
- d  $18 \text{ cm}^2$

- 26** The table below shows the number of pennies Anne places in a jar each day. The pattern continues. Complete the table for Days 5 and 6.

Anne's Jar

Day	Number of pennies placed in the jar
1	1
2	2
3	4
4	8
5	
6	

On what day will Anne place 1024 pennies in her jar?

Justify your answer.

Anne will place 1024 pennies in her jar on Day \_\_\_\_\_.

**27** Farzad puts the following 10 cards into a bag.

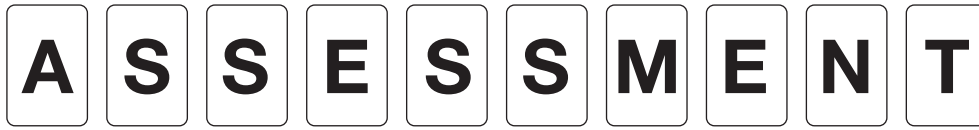

Farzad randomly selects one card, records the result and puts the card back into the bag. If he does this 500 times, how many times is it likely that he will select a card with a vowel (A, E, I, O, U)?

Justify your answer.



**28** The rates for Internet use offered by three companies are shown below.

- Company A: \$6.00 for every 90 minutes of use
- Company B: \$2.75 for every 45 minutes of use
- Company C: \$3.00 for every 60 minutes of use

Which company offers the lowest rate per minute?

Show your work.

Company \_\_\_\_\_ offers the lowest rate per minute.

29 The diagram below shows a square that was moved by a transformation from position A to position B.

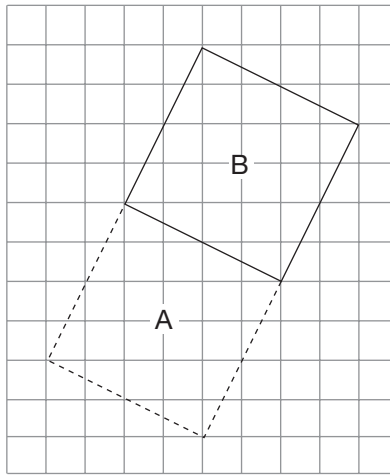

Describe three different ways to move the square from position A to position B. Each way should use a different type of transformation. Remember to include the mirror lines or the centre of rotation on the grid.

Complete the following chart.

Type of Transformation	Description

- 30** Consider the following pattern rule.

Triple each term to get the next term.

Which pattern matches this rule?

- a 0, 3, 6, 9, 12  
 b 0, 3, 9, 27, 81  
 c 1, 3, 9, 27, 81  
 d 1, 4, 7, 10, 13
- 31** Amir's class has 24 students. There are 15 boys in the class. Which of the following represents the ratio of girls to boys?

- a 24:9  
 b 9:24  
 c 5:3  
 d 3:5

- 32** Mr. Price's class collects a total of 1943 pennies over a period of 4 weeks. Samantha brings 125 pennies each week.

Approximately what percent of the total number of pennies collected does Samantha bring?

- a 10%  
 b 25%  
 c 50%  
 d 75%

- 33** Look at the parallelogram below.

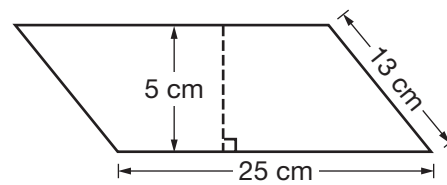

Dylan wants to split the parallelogram into two congruent triangles.

Which expression can he use to find the area, in square centimetres, of each triangle?

- a  $(25 \times 5) \div 2$   
 b  $(25 \times 5) \times 2$   
 c  $(25 \times 13) \div 2$   
 d  $(25 \times 13) \times 2$
- 34** Chris, Paul and Carla share the cost of renting a video game.

- Chris pays 0.4 of the cost.
- Paul pays 36% of the cost.
- Carla pays the remainder of the cost.

What fraction of the cost does Carla pay?

- a  $\frac{6}{25}$   
 b  $\frac{9}{25}$   
 c  $\frac{19}{25}$   
 d  $\frac{24}{25}$

35 The spinner below has 10 equal sections.

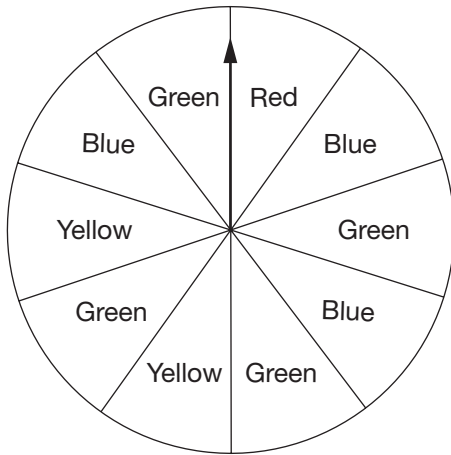

On which colour will the arrow land with a probability of 0.2?

- a red
- b blue
- c green
- d yellow

36 The pictograph below shows the number of students who ride the bus to school.

Students Riding the Bus

Grade	Number of students
5	X X X X X X X X X X
6	X X X X X X X
7	X X X X X X
8	X X X X X

Key
Each X represents 5 students.

Which bar graph represents the same data?

a Students Riding the Bus

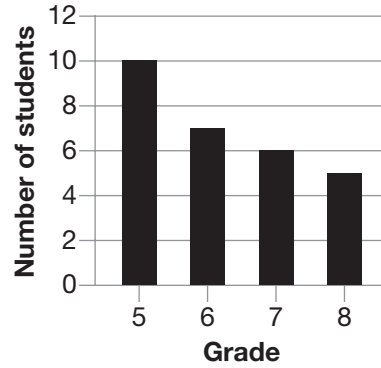

b Students Riding the Bus

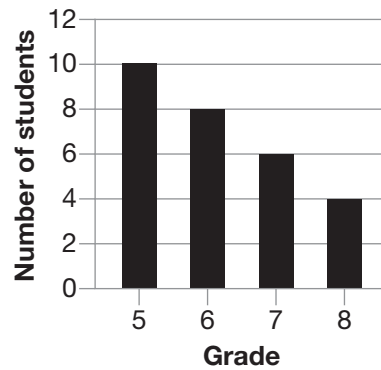

c Students Riding the Bus

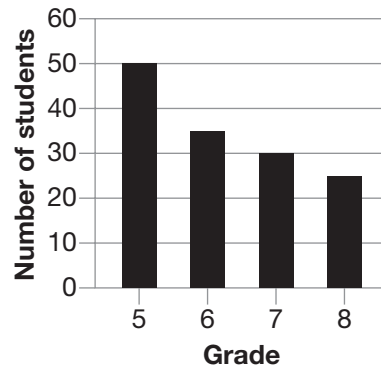

d Students Riding the Bus

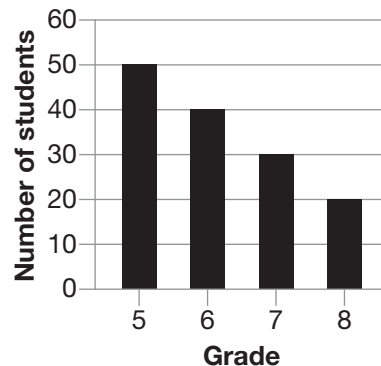

***You have finished***



***this activity.***

**Education Quality and  
Accountability Office**



2 Carlton Street, Suite 1200, Toronto ON M5B 2M9  
Telephone: 1-888-327-7377 Web site: [www.eqao.com](http://www.eqao.com)

© 2010 Queen's Printer for Ontario